Installation Guide

FlexiDim™ Lighting Control System



© Copyright John Clayton Lighting Ltd, 2002-2017.

All Rights Reserved.

Information in this document is subject to change without notice and does not represent a commitment on the part of John Clayton Lighting Ltd.

FlexiDim™ is a Trademark of John Clayton Lighting Ltd

Windows® is a registered trademark of Microsoft Corporation.

Acknowledgement is made of all other trademarks, registered trademarks and trading names mentioned in the text.

Updated 02/2018.

TABLE OF CONTENTS

1. Introduction	4
2. Installation Overview	5
3. FlexiDim™ Wiring Overview	7
4. Components Of The FlexiDim™ System	8
<i>FlexiDim™ iPad Connectivity</i>	11
<i>FlexiDim™ Dimensions, Environmental Limits and Approvals</i>	12
5. Preparation For Installation	14
6. System Wiring	16
<i>Mains Wiring</i>	16
<i>Low Voltage Wiring</i>	21
<i>Wiring other FlexiDim™ Components</i>	22
<i>Wiring a FlexiDim™ System with more than 16 Switch cables</i>	26
<i>Switch numbering</i>	27
7. Initial Power-Up & testing	28
APPENDIX A: In the Event of Failure...	30
APPENDIX B: Adjusting The Switch Plate LED Brightness	31
APPENDIX C: Installation Templates	32

1. INTRODUCTION

FlexiDim™ is simple, fast and cost effective both to install and to commission.

This guide explains the various system components, the relationships that exist between them and the correct connection and cable types. This is followed by a step-by-step explanation of the installation process.

It is essential that the Installer of this system takes some time to read this guide and to become familiar with the concepts of this system, and also with the key differences between FlexiDim™ and a conventional lighting installation.

In particular, please pay attention to any items appearing in the Errors and Omissions section (Appendix C); it is advisable to read this section in advance in order to be aware of any changes required during the installation process. Whilst efforts are always made to keep errors and omissions to an absolute minimum, manufacturing mistakes do occasionally occur and JCL apologises in advance for any entries in this section.

In addition, the Manuals section of the JCL Website www.jclighting.com contains much more information pertinent to wiring and connecting up the various components of the system, including a Wiring Overview diagram.

As with any other electrical installation, it is important that the current, relevant Wiring Regulations are adhered to when installing the FlexiDim™ system.

The system is designed to be installed by a qualified Electrician or other competent person working to current regulatory standards.

For further advice or for an explanation of anything that is unclear, please contact JCL as follows:

Phone: 01507 588558

Email: support@jclighting.com

2. INSTALLATION OVERVIEW

The most immediate difference between conventional lighting and lighting controlled by the FlexiDim™ system lies in the cabling requirements. These are summarised below:

- The switch plates do not have mains cabling, but are wired back to the FlexiDim™ Scene & Switch Controller with Cat.5 UTP cable. Up to 8 switches can be daisy chained on each returning cable.
- The Central Controller should be supplied from its own 6A type B MCB (miniature circuit breaker) in the consumer unit, via a double-pole fused switched spur (fused 3A) to provide local isolation.
- All lighting circuits are wired individually back to a FlexiDim™ Dimmer Module which provides the Live, Neutral and Earth connections for that circuit. Thus, 6 ceiling downlights (forming one circuit) would be connected together in the normal way, and a single mains cable (1mm² or 1.5mm² Twin and ECC, typically) is run back to the Dimmer Module that will be controlling that circuit. A Dimmer Module can control up to 8 lighting circuits.
- Each Dimmer Module can control up to 600VA per circuit, providing that the total for the 8 circuits combined is 2400VA or less. Typically, each Dimmer Module will control a mix of larger and smaller circuits to keep within the 2400VA maximum. Modules are available for larger loads. Dimmer Modules provide self-resetting short circuit and overload protection.
- For added protection against losing all the lights in one area when an MCB trips, it is strongly recommended that where there are several circuits within a single room, they are split across multiple Dimmer Modules. There is no need for all circuits in a room to be on the same Dimmer Module.
- Each Dimmer Module should be supplied from its own 10A type B MCB in the consumer unit, via a double-pole switch to provide local isolation.
- FlexiDim™ can also control wall sockets for lighting use, although these should be fitted using a socket which is visibly different from standard ring-main sockets, in order to prevent the unintended connection of non-lighting appliances such as vacuum cleaners, televisions, etc. Therefore we recommend 2A or 5A round-pin sockets for this purpose.
- A typical installation will have a Scene & Switch Controller and between 1 and 32 Dimmer Modules (controlling up to 8 circuits each), depending on the number of circuits on the system and their loads.
- A Cat.5 UTP cable is required from the Scene & Switch Controller to each Dimmer Module in order to send dimming information. The Dimmer Modules, are chained together. There are two dimmer connections A & B, each supporting up to 16 modules (128 circuits).
- In addition to the Switches, Scene & Switch Controller and Dimmer Modules already mentioned, FlexiDim™ has a number of other units such as Mains Relays (for on/off switching), Blind Controllers, Modules for fluorescent lamps, Modules for LEDs, Remote Control Interfaces and much more. These are all easily connected with Cat.5 to/from the Scene & Switch Controller. Please refer to Chapter 4 for specific details for each of the modules that make up your particular system.

- Provision must be made to connect the Scene & Switch Controller to your Local Area Network (LAN). There is a network socket inside the FlexiDim™ Scene & Switch Controller which is simply connected to the user's network using a Cat.5 network cable. This allows simple wired or wireless network connection to the system at any time, and (usually) from multiple locations in the property. HomePlugs can be used to establish this connection over the building's mains wiring. (We recommend TP-Link AV600)
- FlexiDim™ is configured using a free app for iPad, which can be downloaded from the App Store.
- The FlexiDim™ configuration software allows circuits and switches to be given meaningful names, associations to be made between each switch plate and the lights it should control, and the various moods, automatic sequences etc. to be created. Generally somebody from JCL or one of its Distributors would carry out this task, although this is not obligatory if the installer/end user feels confident to do this work themselves.

3. FLEXIDIM™ WIRING OVERVIEW

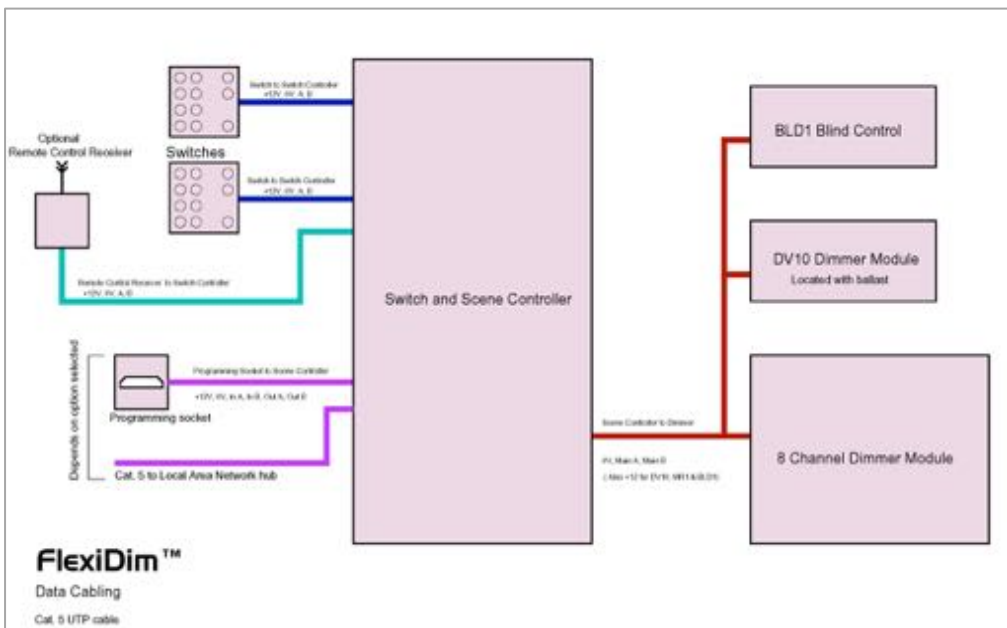
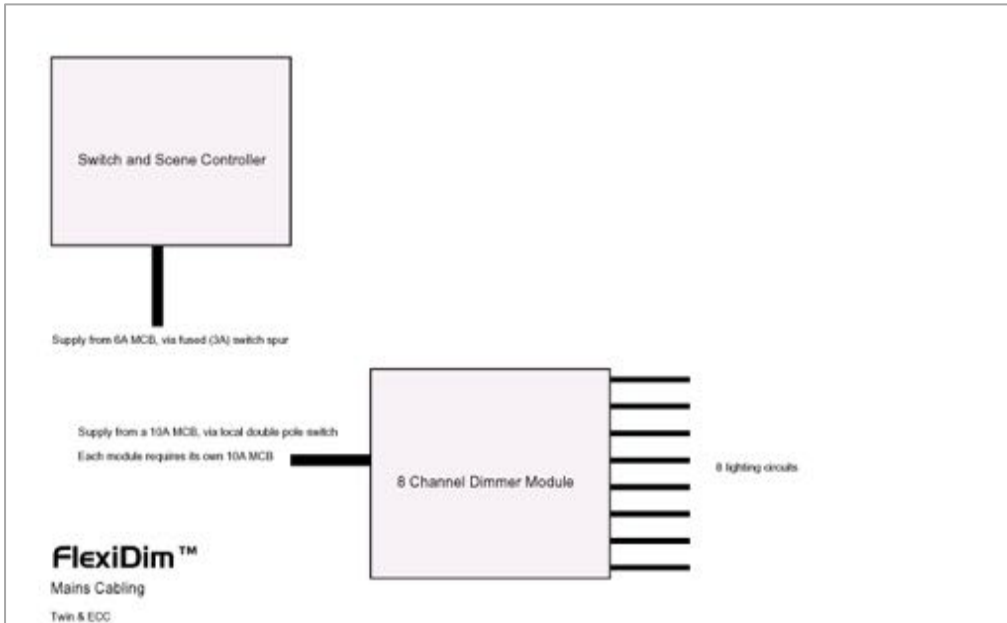

FlexiDim™ Wiring Overview

4. COMPONENTS OF THE FLEXIDIM™ SYSTEM

Scene & Switch Controller

The FlexiDim™ Scene & Switch Controller consists of a Scene Controller board and a Switch Controller board combined in the same case. The Switch Controller is the lower board and the Scene Controller is the upper board. A Power supply is fitted at the bottom end of the Switch Controller board.

The Switch Controller 'listens' to messages from Switches and combines these onto a single cable which then feeds the Scene Controller.

Up to 128 Switches can be connected to a single FlexiDim system.

The Scene Controller listens to the messages from the Switch Controller, interprets the required Scene changes and sends control messages to the Dimmer Modules (which in turn vary the power to the lights).

During commissioning, as many as 2000 Scenes or Moods can be created and assigned to any of the buttons on any of the Switches.

The Scene & Switch Controller is shipped with a pre-loaded configuration that maps all switches to all lighting circuits allowing for easy testing of cabling and to provide basic site lighting.

The Scene Controller is aware of sunrise and sunset time throughout the year and fully supports Daylight Saving Times. Automated Security Sequences can also be quickly created with the Configuration App.

8-Channel DimmerModule IGBT8

Each Dimmer Module regulates the mains supply to 8 Channels of lighting using a technique called hard fired phase control. Both leading and trailing edge are supported. In plain language, this means that the light is switched on for part of the mains cycle, thus regulating the brightness of the lamp

By controlling the exact point of switching to within a few millionths of a second, very precise control is obtained over light levels and the way these levels change from one value to another.

Each Channel of a Dimmer Module is identical and can control a load of up to 600VA, however there is a limit of 2400VA for the overall Dimmer Module (8 Channels). Given a typical mix of light fixtures, the overall rating of a Dimmer Module is unlikely to be reached in the majority of settings.

A FlexiDim™ system controls up to 256 separate Channels (i.e., up to 32, 8 Channel Dimmer Modules).

During commissioning, Channels are given meaningful names and each Channel is configured to give optimal control over the connected load.

The Dimmer Module is shipped with a default brightness of 100% on each Channel, allowing the provision of site lighting by simply applying power to the unit. It is not necessary to have the Scene & Switch Controller or the switches connected for this functionality.

Fluorescent Dimmer Module (DV10) - Now mainly superseded by LED Tape

It is not possible to dim fluorescent lamps using a conventional type of dimmer, as the arc in the lamp will flicker and collapse. Therefore manufacturers produce special electronic ballasts that have a separate control for dimming, while the incoming mains supply remains constant.

FlexiDim™ offers a DV10 Module which is installed adjacent to the high frequency dimming ballast that it will control. The DV10 requires a Cat.5 cable from the Scene & Switch Controller which provides a +12 V supply and dimming information. The DV10 generates the dimming information required by the ballast, and this Module can be used to control up to 10 ballasts which are to dim in unison (i.e., as a single circuit).

The mains supply for the high frequency dimming ballast is cabled separately (using Twin and ECC) from a channel on a Dimmer (or Mains Relay) Module, programmed for fully on/off only.

This module can be used for any dimmable unit requiring 1–10V control.

Mains Relay Module MR4/8

Where on/off switching but not dimming is required (for example, with a non-dimmable lamp type, an extractor fan or water feature pump), Mains Relay Modules can be used, as they provide a cheaper alternative to a Dimmer Module Channel for these applications. Both Solid State (with zero crossing switching), and Conventional relay types are available. In both cases, the maximum load per module is 2400VA and the maximum load per channel is 1000VA.

For the purposes of installation, the 4-Channel and 8-Channel Mains Relays are treated in exactly the same way as an 8-Channel Dimmer Module. Note that these modules supply the mains to the circuit under control in the same way as the Dimmer Module.

Uncommitted (volt-free) relays are also available.

LED Controls

Transformers or drivers for LEDs typically fall into two categories; Constant Voltage and Constant Current. Consequently, the LEDs that are connected to these must be appropriate for the type of driver/transformer used. Your LED supplier can advise on the correct driver for their product.

Constant voltage drivers are basically a power supply with a DC output (rather than AC, as is the case for low voltage halogen). Multiple LEDs are connected in parallel and the voltage of the LED must match the voltage of the power supply; typically 12 or 24V.

Constant current LED drivers require that the LEDs are wired 'in-series'. The most common types are Luxeon® or LumiLED®, which operate from a 350mA or 700mA constant current source, depending on power output. These are currently the brightest types. For technical reasons, they are also better at dimming and will dim smoothly from 1–100%, making them ideal for colour changing applications.

If dimming is not required, the appropriate driver can be supplied from a channel on a Dimmer or a Mains Relay Module.

If Dimming is required, the driver should be specified with DMX control as a preference or 1–10V control as an alternative. Main dimmable drivers are also widely available, which can be dimmed from a channel of a Dimmer Module in the usual way.

JCL offers a DMX interface to control DMX compatible drivers, or the DV10 Module can be used for drivers requiring 1–10V control.

Blind Controller

The Blind Controller provides sequenced relay contacts to signal motor direction and duration to blind motors, window motors etc. A variety of configurations are available to suit all types of blind. Specify the manufacturer and Model of Blind/Actuator when ordering.

Note that if 2 or more blinds/curtains are required to operate together, then they must have the same travel time from open to closed and vice versa (i.e., the windows will need to be the same size).

Switches

FlexiDim™ Switches do not control mains power directly, but send messages to the Dimmer Modules via the Scene & Switch Controller. The supply to the Switches is 12V from an isolated supply.

The cabling required to the Switches of a FlexiDim™ system is low voltage using Category 5 UTP cable.

Each Switch Plate consists of either 4 or 8 user-definable Scene buttons, as well as the standard Dim Up, Dim Down and On/Off buttons (see diagram below).

Switches ‘advertise’ their button layout automatically during system Commissioning, therefore there is no need to configure or cable the FlexiDim™ system differently depending on the type of Switch installed at each location.

During the Commissioning process, Switches are given a meaningful name such as ‘Hallway’ or ‘Dining Room’ depending on their location, and then their relationship to the lighting circuits is defined.

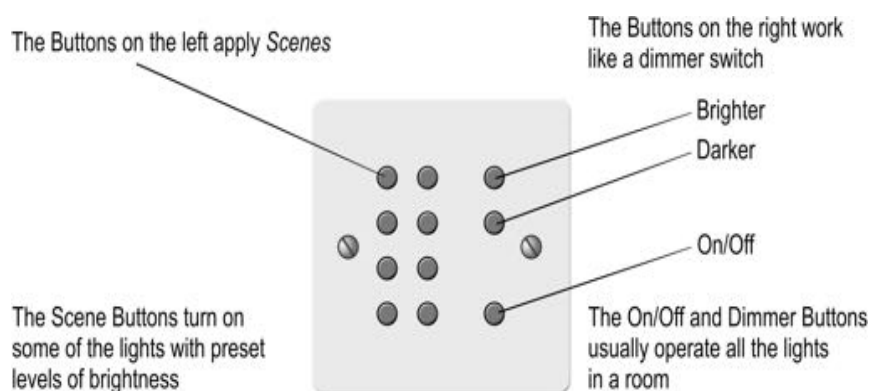

Typical FlexiDim™ Switch Plate layout

Optically Isolated Switch

Optically-isolated switches for use with motion detectors or other types of switches are also available as part of the FlexiDim™ system.

These appear to the system as either 2 or 8 button switches, and the buttons are 'pressed' by closing or opening a contact across the inputs to the Optically Isolated Switch. This might be the opening of a PIR contact when it detects motion, the set/unset contacts on an alarm panel or a simple pushbutton in an area that does not justify a switch with mood presets, such as a utility room.

Each contact can be individually configured for normally open or normally closed operation as well as auto-repeat.

Remote Control Components

FlexiDim™ offers a variety of remote control solutions.

The most straightforward is using your iPhone, iPad or iPod Touch in conjunction with the iPad Configuration Utility.

Crestron/AMX/Control4/Savant etc. are fully supported via serial as well as TCP connections.

DALI

An Interface that will control DALI fittings is available, although we do not recommend DALI as the data rate is too low for effective architectural lighting control.

FlexiDim™ iPad Connectivity

TCP/IP Interface

The FlexiDim system plugs into your network – usually a socket on the broadband router. HomePlugs can be used to establish this connection, if the router is in a location that makes running a network cable from the Scene Controller difficult.

FlexiDim implements its own dynamic DNS system that avoids the need for a static IP address in order to take advantage of remote connections across the public internet. All connections are encrypted to AES128 standard. (Some simple configuration of the broadband router is required for remote access.)

FlexiDim™ Dimensions, Environmental Limits and Approvals

Combined Scene & Switch Controller
Expansion Switch Controller I16/C
Dimmer Module IGBT8
Mains Relay Module MR4/8
FlexiDim Switch Plate (4/8 Scene)

Case dimensions

Scene & Switch Controller, Dimmer Module, Mains Relay Module, Blind Controller:

260mm high x 190mm wide x 90mm deep
Wall mounted, cable access from rear.

Switch Plates:

90mm x 90mm x 1.6mm
Fitted in standard UK single wall box (35mm deep).

Case clearances required at installation

Controller:

Top & bottom	50mm
Sides	20mm

Dimmer Module, Mains Relays Module, Blind Controller:

Top & bottom	100mm
Sides	50mm

Environmental and Power requirements

All components:

0°C to 40°C, 0–90% humidity non condensing

Controller:

220–240V 50Hz AC, 30W

Dimmer Module, Mains Relays Module, Blind Controller:

220–240V 50Hz AC, 6W (plus lighting load)

Approvals:

EN 60335-1
EN 50081-1
EN 50082-2
EN 61000-3-2
EN 55015 (Dimmer Module IGBT8)
EN 60335-1



Combined Scene & Switch Controller (SC2) and Expansion Switch Controller (SW2X)
 (Note: Expansion Switch Controller SW2X does not have the network interface/controller boards installed)



Dimmer Module IGBT8



Mains Relay Module MR4/8

5. PREPARATION FOR INSTALLATION

Prior to installation of the FlexiDim™ equipment, all the lighting circuit, data and power supply wiring must be completed, clearly labelled and tested in accordance with current wiring regulations.

FlexiDim™ Installation Mounting Board

The FlexiDim™ Controller and Dimmer Modules are wall-mounted and cabled from behind.

Therefore, the neatest and most practical way to install the units is to batten out the wall to be used for the installation and then to use a piece of 18mm MDF or plywood for the mounting board.

The mounting board can then be pre-drilled with all the cable holes and the appropriate cables pulled through each hole prior to installation of the FlexiDim™ units.

Each Dimmer Module will have the following wiring coming in:

- mains cables for the circuits being controlled,
- the cable supplying mains power (from the double pole switch)
- Cat.5 cables from the Controller and/or the next/previous Dimmer Module

The Controller will have the following wiring coming in:

- the cable supplying mains power (from the fused switched spur)
- the Cat.5 cables from the switch plates
- the Cat.5 cable out to the Dimmer Modules

There will also be a Cat.5 cable plugging into the building Local Area Network (for connectivity with a PC or laptop for system Commissioning and Programming).

Locations should also be confirmed for ancillary items such as Optically Isolated Switch inputs (normally on the same mounting board), RF receiver (typically centrally within the property and at high level) and LED drivers/power supplies. These will be detailed in the notes section of the Installation Specification for the Property.

Installation Templates

Paper templates for the main FlexiDim Modules (Scene & Switch Controller, Dimmer Module, Mains Relay Module) can be supplied if required. These paper templates can be taped to the installation mounting board and then used for drilling the holes required for each of the cables. These templates also show the minimum spacing required between each of the units to allow for maintenance access

If required, JCL can also provide a recommended layout for the Installation Mounting Board (once the wall size for the installation is confirmed)

An example of an installation mounting board layout is provided on get next page.

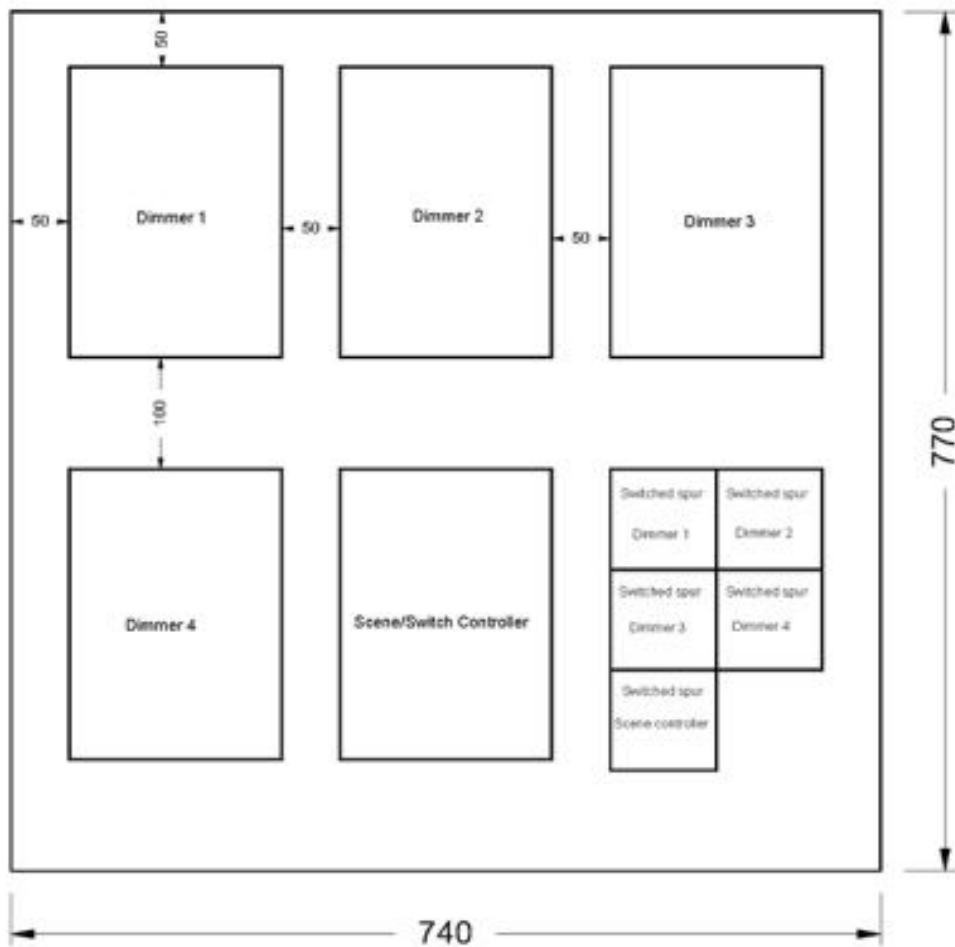

Example Installation Mounting Board Layout

A minimum of 300mm should be allowed between the top of the Dimmer Modules and the ceiling of the installation location to ensure proper air circulation. In shallow cupboards, additional ventilation provision may be required.

6. SYSTEM WIRING

Unlike a traditional lighting installation, where the mains wiring progresses from one ceiling rose to the next with the switch cabling interrupting the live circuit to the lamp, a centralised dimmer needs slightly different wiring.

Mains Wiring

Scene & Switch Controller

A switched fused spur is required for the Controller power supply. This power supply is housed in the Controller case. A switch should be located near to the case and a 3 A fuse should be fitted. It is recommended that the Controller be fed from its own MCB (6A) rather than as a spur from the property's ring-main. This is to prevent the lighting system be affected by an MCB or RCD trip caused by another device.

All the switched spurs should be clearly labelled with the component that they supply, for example "FlexiDim™ Controller", "Dimmer Module n", etc.

Dimmer Modules / Relay Modules

Mains power is fed from the consumer unit to each Dimmer Module via an appropriate MCB (miniature circuit breaker). 10A type B should be used. The soft start built into the Dimmer Module avoids the need for Type C to accommodate high in-rush currents.

Each of the Channels to be controlled is then cabled from the Dimmer Module to the light fittings.

- Note that each Dimmer Module should be fed via a 20A double pole switch, accessible by the end user. This is essential to allow isolation of the Dimmer Module for servicing or for bulb changing.

Unlike an installation with conventional light switches, with a FlexiDim™ system there is the real possibility that someone elsewhere in the property could activate a light whilst a lamp is being changed.

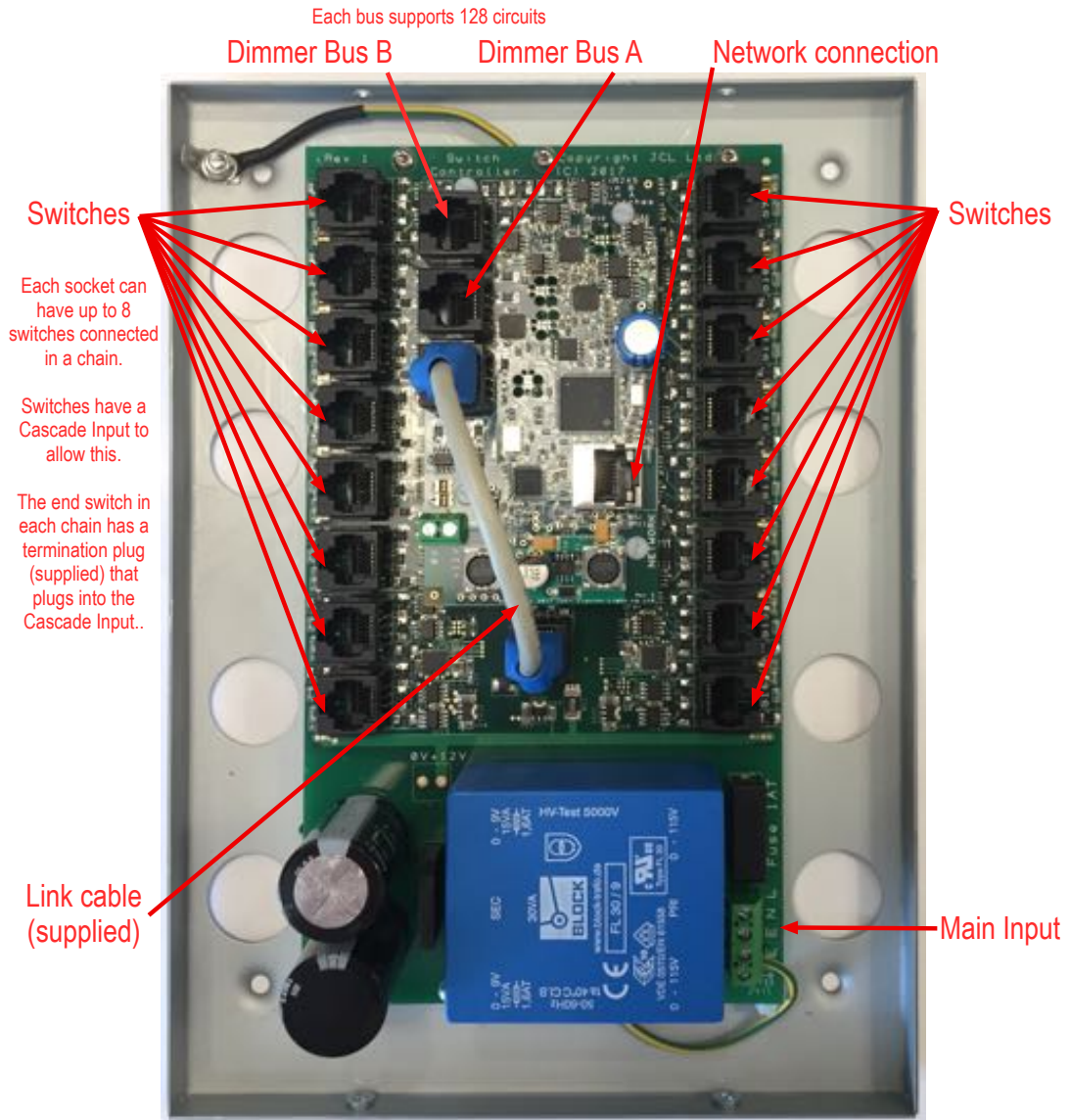

Enhanced Scene and Switch Controller

The Enhanced Scene Controller uses RJ45 connectors for all data connections. Standard RJ45 patch cables can be used –i.e. all contacts connected 1-1

If it is installed in the same enclosure as the Enhanced Switch Controller, the green power connector is not used as the power for the unit is provided via the Link cable from the Switch Controller board.

The switch farthest from the controller – even if the chain consists of a just a single switch – should have an ‘End Of Line’ connector plugged into the Cascade In socket. These are provided with the system (one per switch input).

If more are required, they can be made up by looping pins 1 to 5 and 2 to 4 in an RJ45 plug. i.e. White/Orange to White/Blue and Orange to Blue.

Micro Scene Controller

To reduce the cost of implementing smaller systems, the Micro Scene Controller is available.

It is functionally identical to the Enhanced Scene and Switch Controller, except that only a single chain of switches can be connected. Up to 8 switches can be connected, one to the next, and then directly into the Micro Scene Controller. Each switch has separate RJ45 connectors for data out and data in from the previous switch in the chain.

It comprises the Scene Controller board mounted on a double gang plate and fits into a 47mm deep wall box, usually surface mounted adjacent to the Dimmer Modules. A plug-top power supply is provided to power the Scene Controller and switches, so a 13A socket will be required adjacent to its location.

It uses RJ45 connectors for all data connections. Standard RJ45 patch cables can be used –i.e. all contacts connected 1–1

The switch farthest from the controller – even if the chain consists of a just a single switch – should have an ‘End Of Line’ connector plugged into the Cascade In socket. This is provided with the system.



8-Channel Dimmer Modules

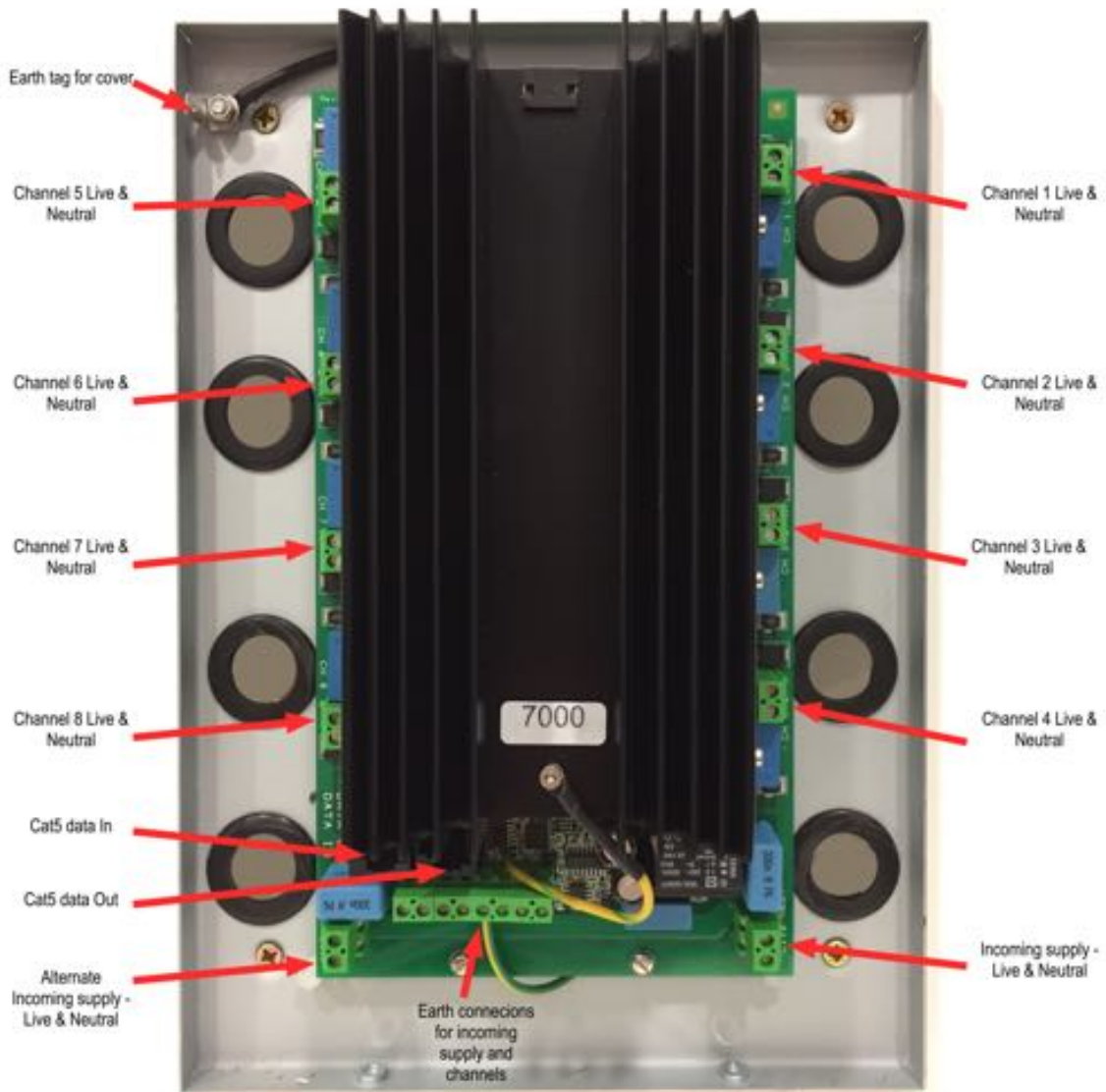

FlexiDim™ Dimmer Module wiring

It is recommended to first route the earth connections to the bottom of the Dimmer Module, then to route the load neutral connections to their terminal blocks, and finally connect the load lives to the Channel outputs. This will provide the easiest way of neatly routing cables within the enclosure.

Mains Relays

For the purposes of installation and commissioning, the 4-Channel and 8-Channel Mains Relay Modules are treated in exactly the same way as a Dimmer Module.

The connection points for the cabling within the Mains Relay are identical to the Dimmer Module even though the appearance of the units is different.



Low Voltage Wiring

Unshielded Category 5, Cat.5E, or Cat.6 cable should be used for the low voltage data cabling of the FlexiDim™ system. This provides 4 pairs.

The allocation of pairs is as follows:

- Brown/White–White/Brown +12V (2 pairs used)
- Green/White–White/Green 0V (2 pairs used)
- Orange/White Data A
- White/Orange Data B
- Blue/White–White/Blue Data A & Data B return channel

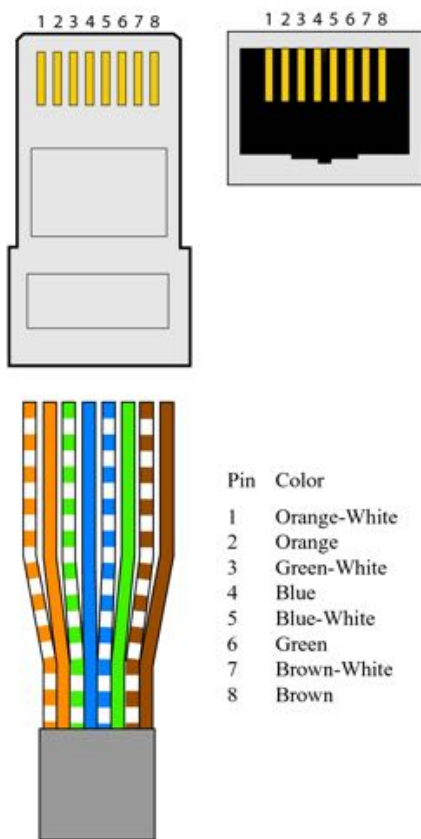

Scene Controller to Dimmer Module Wiring

Dimmer & Relay Modules requires a single Cat.5 cable to be run to them from the Scene Controller Dimmer Bus A and/or Dimmer Bus B connectors. Bus A controller channels 1 – 128, channels 129 – 256 are on Bus B.

Where multiple Modules are installed, these cables should be run from one Dimmer Module to the next ('daisy chained'). To daisy chain the dimmer wiring, use the output RJ45 socket on the Dimmer Module (marked Data Out).

Wiring other FlexiDim™ Components

1-10V (DV10) Modules

Fluorescent Dimmer (DV10) Modules are designed to be located adjacent to the high frequency dimmable ballast (or other device) that they control.

The DV10 interface is 20mm diameter and 120mm in length.

A Cat.5 cable, from the Scene Controller, is required to each DV10 which should be terminated in an RJ45 plug, conforming to normal Ethernet colour code.

The DV10 module provides a 1–10V control signal to dim the ballast. The mains supply for the device's ballast/driver is provided from a channel on a Mains Relay or Dimmer Module. The mains relay or dimmer channel simply provides on/off control for the circuit while the DV10 effects the dimming via its 1–10V output.

- Orange / Red wire + input on the ballast/driver
- Grey / Black wire - input on the ballast/driver.

On later versions, the 1–10V output is on pins 4 (White/Blue) and 8 (Brown)

- White/Blue (Pin 4) + input on the ballast/driver
- Brown (Pin 8) - input on the ballast/driver

This module can be used for any dimmable unit requiring 1–10V control.

A voltage less than 1V is guaranteed when the channel is at 0%.

8-Channel DMX Controller

DMX modules are designed to be located adjacent to the driver that they are controlling, the location for which will depend on the distance from the LEDs to the main equipment cupboard. Refer to the instructions provided with the LEDs and driver. The DMX interface is 20mm diameter and 120mm in length.

A Cat.5 cable, from the Scene Controller, is required to each DMX interface which should be terminated in an RJ45 plug, conforming to normal Ethernet colour code.

An RJ45 connector is supplied with the DMX module, which will plug into many DMX compatible drivers. If this is not suitable, the end can be removed and the cable colours are as follows:

- White/Orange DMX +
- Orange DMX -
- Brown 0V

Refer to the driver documentation of the correct connection points.

As the DMX standard allows for a fully off setting, the driver will normally be provided with permanent mains supply – often from a 13A socket near to the driver.

1-10V / DMX Distribution Board

The Scene Controller has a single output for dimmer data on each Dimmer Bus, which is normally connected to the first Dimmer Module and then daisy chains between subsequent Dimmer Modules.

As 1-10V and DMX Modules have their own cable, a distribution board is available that has an input that connects from the Scene Controller dimmer data connector and 8 output connectors for connections to 1-10V and DMX Modules as well as the Dimmer Modules Chain.

Distribution boards can be cascaded if more outputs are required. Depending on the number of DV10 and or DMX modules, a separate plug-top power supply may be supplied.

2-Channel or 8-Channel Optical Switch

To the system, these modules appear as a switch plate. They are wired into the Switch Controller board in exactly the same way as a normal switch plate.

2-Channel Optical Switch

The 2-Channel Optical Switch has an additional terminal block marked SW1 and SW2. Connect the contacts that will activate the Opto-Switch to SW1 and SW2 as required. Insert the links for normally Open (NO) or Normally Closed (NC) operation for SW1 and SW2 as required. PIR detectors are usually NC, while push buttons are usually NO.

If power is required for the PIR, take this from the +12V and 0V terminals on the larger connector (from the Scene/Switch Controller).

8-Channel Optical Switch

The 8-Channel Opto-switch has a connector to the Scene/Switch Controller which is cabled in the same way as a switch plate. There are terminal blocks to distribute +12V and 0v on either side. At the bottom of the board are 8 pairs of inputs marked + -

There are several ways of using the 8-Channel Opto-switch, but the objective is to provide (or interrupt) +12V across the + and - input of a channel in order to signal to FlexiDim™.

PIR with Normally closed contact

Cable +12V to the PIR, 0V to the PIR, - to a NC contact in the PIR. Insert a link between +12V and + for the channel being used at the Opto-switch. Insert a link in the PIR between 0V and the other NC contact.

Push Button

Cable 0V to the push button and - to the other terminal on the push button. Insert a link between +12V and + for the channel being used.

On the 8-Channel Opto-switch, normally Open/normally closed operation as well as “auto-repeat while pressed” operation for each channel is configured via a setup procedure. There are no links to determine this, as was the case with the 2-Channel Opto-switch.

Setting Up Normally Closed or Normally Open Operation

When the module is first powered up, the LED will blink red and green for 30 seconds. This allows PIR detectors to initialise and provide a stable output. No data is sent to FlexiDim™ during this time.

Depending on the type of device connected to the inputs, it is necessary to program the module to detect contact closure or contact opening. This is achieved by holding the button on the module for 10 seconds. The LED will turn on red for 2 seconds and then turn off.

The state of each input when the LED turns on is considered the normal or quiescent state. Therefore ensure that no buttons are pressed and any PIRs are not detecting movement.

When a contact is detected in the active state, a message is sent to FlexiDim™. The message is repeated every 10 seconds for as long as the input is active.

Blind Controller

The location of the Blind Controller is flexible, but should be accessible. In most cases, alongside the other FlexiDim™ components is suitable.

The relay contacts on the Blind Controller are volt-free and the connections will depend on the type of blind/actuator being used. The site-specific documentation will specify the wiring for the 8 wires coming from the Blind Controller Module.

The Blind Controller Module requires a Cat.5 cable from the Scene Controller, and is connected in to the same terminal block as the 8-Channel Dimmer Module.

See the website Manuals section (www.jclighting.com) for examples of blind motor wiring.

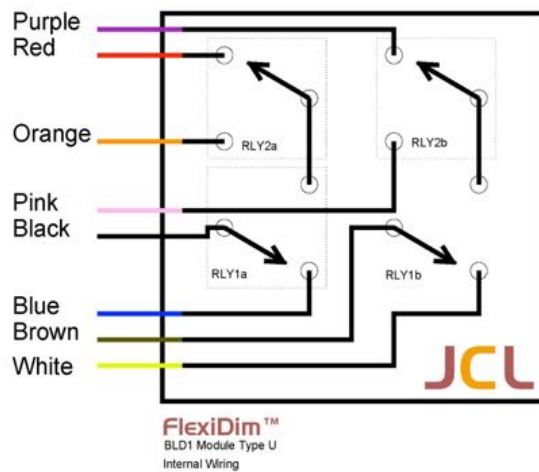

© Copyright John Clayton Lighting Limited 2001-2005

FlexiDim™ Blind Controller Wiring

Wiring a FlexiDim™ System with more than 16 Switch cables

Usually being able to chain up to 8 switches on a cable will mean that 16 or fewer switch cables return to the Switch/Scene Controller.

However, if a system has more than 16 chains of Switches, another Switch Controller board is required. This may be the case if it is not practical to chain switches efficiently, and more than 16 switch cables are returning to the Switch/Scene Controller as a result.

Another reason for using an Additional Switch Controller is to allow a wiring hub (to minimise cabling) in an especially dispersed installation.

Additional Switch Controllers simply cable to a switch input on the Main Switch Controller.

The main Switch Controller will detect the presence of an Additional Switch Controller (as opposed to directly connected Switches) and will configure itself accordingly.

Switch numbering

The Main Switch Controller has 16 input connectors, with 8 switches being allowed on each for a maximum of 128 switches.

Input 1 will be switches 1–8, input 2 will be switches 9–16 and so on. The Configuration App can detect the switch number during initial configuration by asking you to press any button on a switch and listening for the incoming message.

This allows switches to be added (up to the maximum or 8 per input) without interfering with the numbering of switches on other inputs.

Numbering with an Additional Switch Controller

When an Additional Switch Controller is used, switch numbering is handled slightly differently. Internally, the Additional Switch Controller numbers switches incrementally rather than in blocks of 8.

For example:

Input 1 has 3 switches in a chain – these will be switches 1,2 & 3

Input 2 has no switches

Input 3 has 2 switches – these will be switches 4 & 5

Input 4 has a single switch – this will be switch 6

Input 5 has 6 switches – these will be 7,8,9,10,11,12

...and so on. These numbers are then offset to the starting number for the socket on the Main Switch Controller into which the Additional Controller is plugged to give the final switch number (Final switch number is actually 'Local Number' + 'Starting Number for socket on Main Switch Controller' -1).

Adding a switch will cause all switches further down the list to move up, changing their number. This will need to be addressed in the Configuration App, so it is better to have all switches connected before starting configuration. Add additional switches beyond existing switches whenever possible.

If an Additional Switch Controller has more than 8 switches, make sure that space is left for the switches by ensuring that connections on the Main Switch Controller immediately following the point that the Additional Switch Controller is plugged in are left free.

e.g.: 30 switches on Additional Switch Controller are plugged into Input 4 on Main Switch Controller: Ensure inputs 5,6 & 7 on Main Switch Controller are left unused.

Main Switch Controller Input 4 starts at Switch 25.

Switches on the Additional Switch Controller will be numbered 25 through 54 as far as the system is concerned.

7. INITIAL POWER-UP & TESTING

- Note that this stage must only be carried out by a qualified electrician, or other suitably qualified person.
- Note that mains voltage is present within all cases and therefore extreme care should be taken whilst performing initial installation tests on this live equipment if the protective cases are removed.

Having checked all cabling (in particular the polarity of the +12 V and 0 V cables throughout the system), the following steps will test the entire installation. As all units are tested before dispatch, provided that the wiring has been thoroughly checked, the system will work first time.

The following tests should then take about 10 minutes to complete. If at any point the expected result cannot be achieved, please call JCL for advice.

Testing using the Factory Defaults

It is assumed that all mains wiring has been properly tested in accordance with the current wiring regulations and, in particular, that there are no short circuits between Live and Neutral or Live and Earth on any of the lighting circuits.

Damage caused to the Dimmer Module by cabling faults of this type are not covered by the FlexiDim™ warranty and may incur a repair charge.

Do not connect circuits that do not have the light fitting installed or which are not properly terminated/insulated.

A 5A plug wired to a pendant bulb holder is the best way of testing 5A sockets connected to the system.

- Switch on each Dimmer Module in turn. All outputs on the Dimmer Module will switch on within about 15 seconds. Verify that the expected circuits turn on.
- With all Dimmer Modules switched on, turn on the power to the Scene & Switch Controller. The Scene Controller starts within a few seconds. The LEDs can generally be ignored, however their function is as follows:

There is one intermittently flashing green LED adjacent to the Link cable, showing incoming switch messages. Another rapidly flashing green LED shows that the main processor is running. A solid green LED, adjacent to the network socket, shows that the network processor is running. Green and Yellow LEDs on the Network socket itself show network activity. An LED adjacent to the connectors to the Dimmer Modules show that the dimmer co-processor is running and sending data to the dimmer modules.)
- The Switch Controller has red overload LEDs adjacent to each switch input. If these illuminate, there is a cable fault (short between +12V and 0v) for that cable. The other LEDs can generally be ignored, however their function is as follows:

A green LED (just below the upper board, adjacent to each pair of inputs) shows incoming data to the switch inputs (Inputs 1&2 share an LED, as do 3&4, 5 & 6 etc.) There is also a green LED more centrally on the Switch Controller board that shows messages being sent via the Link cable.

- Once the system is running, all the Dimmer Modules will be sent a command to turn off all their circuits and therefore all lights in the installation will be switched off. If this does not occur, then check that the data cable from the Scene Controller is correctly connected to the Data connection on each Dimmer Module.
- The FlexiDim™ system is shipped with all switches programmed to turn all lighting circuits on and off. This allows the whole system to be tested (and used as site lighting) prior to Commissioning and without the need for a computer.
- Press the on/off button on each switch in turn and verify that all lights turn on and off. If a particular switch does not operate, check that switch's cabling. If multiple switches do not operate, check the voltage being supplied to the switches as a short circuit may be dragging the supply voltage down. The red LEDs adjacent to the switch inputs indicates a short circuit. (If this is the case, switch cables will need to be disconnected in turn until the defective cable is discovered.) The design of the FlexiDim™ power supply for the switches is divided so that a shorted cable should only affect switches connected to that input.

These tests have verified the following:

- The main power supply is functioning.
- All Switches are working and the Switch Controller is receiving Switch data.
- The Scene Controller is successfully receiving data from the Switch Controller.
- The Scene Controller can control all Dimmer channels.
- All Dimmer Modules are working correctly and can receive data from the Scene Controller.

Now replace all covers, ensuring that the protective earth cable is connected to the spade terminal on the wall plate and that both screws are properly tightened.

The FlexiDim™ system can now be commissioned using the iPad Configuration App.

APPENDIX A: IN THE EVENT OF FAILURE...

FlexiDim™ is designed to be trouble-free to install and commission, however there is always the possibility of component failure in any complex piece of electronic equipment.

Electronic Component Failure

Before assuming that a FlexiDim™ system component has failed, check the obvious things such as cabling and power. In particular, the integrity and wiring of RJ45 connectors and data cables is important.

The post-installation tests described in the previous sections will have identified the part of the system that is causing the problem. The order of the tests is important, as some tests rely on the correct functioning of previously tested components.

The most common problem at installation will be wiring errors, and the majority of fuses used within the system are electronic self-resetting types.

Mains wiring should of course be checked in accordance with the current regulations.

In the event of a suspected defective unit, please contact JCL. Have the Site ID (printed on the Scene Controller) and the Module ID (if relevant) to hand.

Defective Unit Replacement Process

In the event that a FlexiDim™ unit needs to be replaced, the replacement unit will be supplied free of charge, provided that the unit is within the 5-year warranty period and the defect is due to failure of the unit and not external causes. Otherwise units are replaced as per the current price list.

Note that for any items replaced under warranty, the defective unit must be returned to JCL in an agreed timeframe to avoid being charged for it at the current price.

APPENDIX B: ADJUSTING THE SWITCH PLATE LED BRIGHTNESS

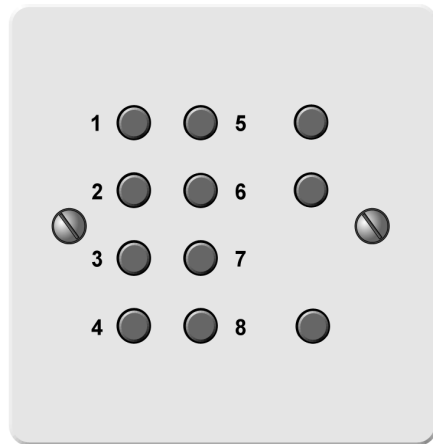

To set the brightness of the LED in the switch plate:

- Press buttons 1 & 4 together and the LED will go off.
- Now press and hold buttons 1 & 4 together until the LED comes back on (this will put the switch plate LED into programming mode).
- Release buttons 1 and 4.
- Use the dim up and dim down buttons to set the LED to your preferred brightness.
- Once you have reached the required brightness setting, press the On/Off button once to save.
- To change the brightness at any time, start again at step 1.

- The brightness of the switch LED can also be adjusted by the Scene Controller as defined by the configuration program, including as a timed event.

APPENDIX C: INSTALLATION TEMPLATES

The following pages contain paper templates that can be used to pre-drill the cable holes in the installation board.

Note that if you are printing this document from the JCL Website, make sure that the templates have printed full size (i.e., that the 100mm line does measure 100mm).